

FlightSafety
international
Simulation

&



**United
Electronic
Industries**

High Performance Real-Time I/O and Control

SimI/O

FlightSafety
international
Simulation

FlightSafety
international
Simulation



Made possible with the new PowerDNR RACKtangle™ from UEI

"Our Sim/I/O software has taken advantage of UEI's PowerDNR I/O in such a way that we can maintain and increase our uptime of 99.6%. We use a COTS based product which is CE certified and interrogate our simulators while running in real-time using the extensive built-in diagnostic features. We can detect if a fault is going to happen and correct it immediately this also allows us to pinpoint faults from the highest level right down to the actual I/O pin."

Ron Jantzen, Director of Engineering, FlightSafety International

Increased up-time: The RACKtangle based Sim/I/O series was designed from the start to provide unprecedented "up time" and reliability. The I/O is mounted directly on the simulator rather than an off-sim cabinet. This eliminates over 80% of the waterfall wiring and dramatically reduces the likelihood of a cable failure. The system also includes a complex level of system diagnostics that identifies pending and/or existing system faults before they impact training schedules.

Higher Performance: The new system is based entirely upon Gigabit Ethernet technology, ensuring the communications between the host computer system and the simulator is extremely fast. The tight coupling of the hardware and real-time operating system software allowed by using a single API and driver also enhances system speed. Having the I/O on-board increases the signal-to-noise ratio due to the proximity of the data acquisition electronics to the signal source. These factors combined allow Sim/I/O simulators to be operated at 2000 updates per second.

Faster repairs and maintenance: The Sim/I/O offers incredible reliability, but no system offers 100% reliability. Once a failure is noted, the key is quick fault identification and repair. Every output in the system can be independently monitored. All inputs can be connected to a test signal. This allows faults to be automatically detected and the system informs the repair technician via wireless notepad exactly where the problem lies and how to correct it. In the time it takes for the instructor and trainees to grab a cup of coffee, the sim is often back on-line.

Secure COTS source: When FSI realized VME product obsolescence could someday adversely impact their ability to build and maintain their simulators, they made the choice to seek out an I/O partner rather than simply select new products from multiple vendors. The partnership formed with UEI ensures a totally secure source of product. Not that supplying OEMs with a continuous source of products is new to UEI. The company still supplies OEM customers with ISA-bus boards designed over 20 years ago!

Additional benefits: The Sim/I/O requires less time to install and reduces "off-simulator" cabinet size by 50%. The tight integration of I/O and the simulator will also reduce the time and effort required to develop simulators for new aircraft.

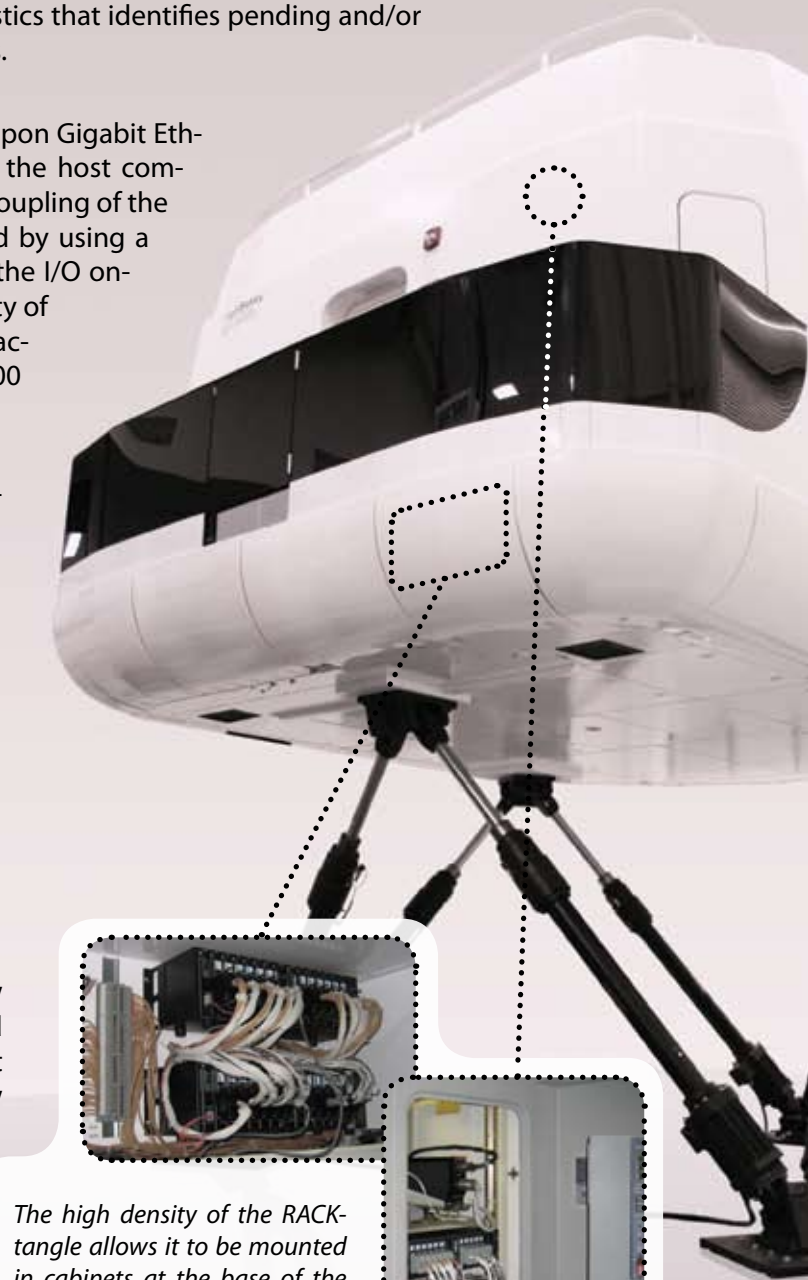

The high density of the RACKtangle allows it to be mounted in cabinets at the base of the simulator (above) or in racks within the simulator (right) rather than in "off-sim" racks.

For more information please download our white paper at: www.ueidaq.com/FSI-RACKtangle

UEI's RACKtangle I/O series provides the entire interface between the host computer and the simulator including; control/loading/motion, controlling and monitoring all flight deck I/O and providing a direct interface to all avionics.

Features (with callouts):

I/O Board Slots (1)

The DNR rack provides 12 I/O slots. All combinations of DNR-series I/O boards are allowed offering over literally trillions of possible configurations. DNR series I/O boards are fully plug-and-play. There is no hardware configuration required. Empty slots are covered with blank panels to maintain air flow, reduce EMI and protect the system from dust accumulation. Your signals may be connected directly to the I/O boards via your custom cabling or take advantage of our wide variety of easy-to-use, external screw terminal panels.

CPU and Gigabit Ethernet NIC Module (2)

The DNR series controller and NIC interface are provided in the center slot. This configuration maximizes system noise immunity by reducing the maximum distance an I/O board may be from the CPU. In addition to providing the CPU, this module provides the two Network/Ethernet ports, the two USB 2.0 ports, the serial configuration port, the recessed reset button, the inter-rack sync interface and the SD Card slot.

Passive Backplane

The backplane of the DNR rack contains no active components. This means the DNR chassis itself offers an almost unlimited MTBF. All active components in a DNR system are on easily replaced boards. The DNR-Buffer module provides the interface between the CPU and the various I/O boards. Placing the drive circuitry on a removable board rather than on the backplane ensures the backplane remains totally passive.

Flexible Mounting (3)

The DNR-series racks include industrial quality rubber feet for table-top applications. The DNR-Bracket kit allows the rack to be mounted on a flat wall or surface or in a standard 19" rack (requires 3U spacing).

Power Supply Module (4)

Power-In, 9-36V DC either from the DNA-PSU-24 (included with the rack), or a user-supplied source. All power supplies are monitored. Power supply status supplied to the CPU module as well as displayed on annunciator LEDs (see layout below).

Protected On/Off Switch (5)

The On/off switch is mounted within two metal shields which ensure the switch will not be inadvertently turned on or off.

Diagnostics & System Health Monitoring

The RACKtangle I/O systems provide significant diagnostic and health monitoring capability including: Current and voltage monitoring on digital outputs, Analog voltage monitoring on digital inputs, Built-in chassis temperature monitoring and more. This allows the system to diagnose and sometimes predict failures before they cause major problems. All function are fully supported by the supplied API.

Rugged and Industrial

All aluminum construction ensures excellent immunity to shock and vibration. Operationally tested from -40°C to +70° C and rated for use up to 70,000 feet. The RACKtangle I/O chassis is fully CE certified.

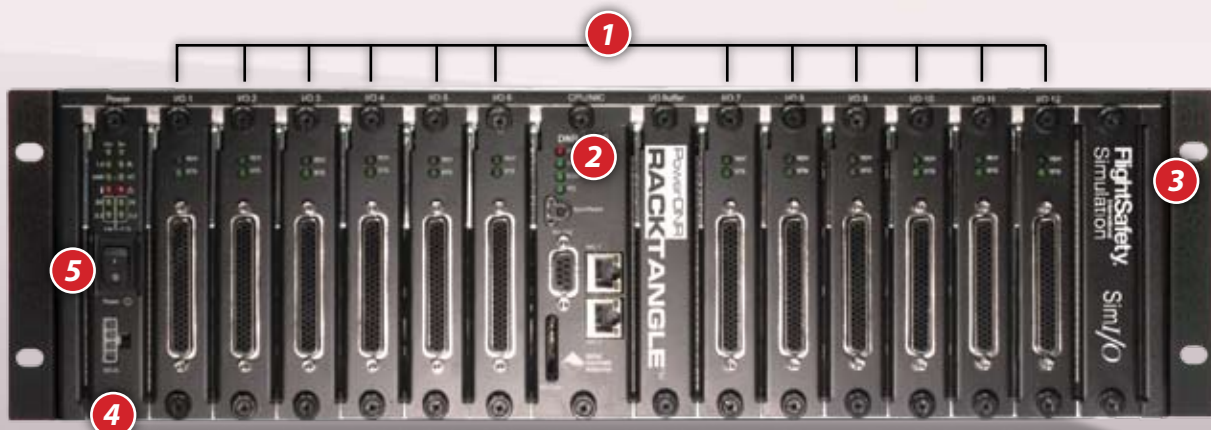

Popular RACKtangle™ I/O modules

DNR-AI-205

- 4 A/D channels
- 18-bit resolution
- Chan to chan isolation

DNR-AI-207

- 16 A/D channels
- 18-bit resolution
- 12 input ranges

DNR-AI-225

- 25 A/D channels
- 24-bit resolution
- ± 1.25 V input range

DNR-AI-254

- 4 LVDT/RVDT channels
- 16-bit resolution
- Provides all excitation

DNR-AI-255

- 2 Synchro/resolver inputs
- 16-bit resolution
- Programmable excitation

DNR-DIO-432

- 32 digital outputs (sink)
- 600 mA output
- Monitors Vout and Iout

DNR-DIO-433

- 32 digital outputs (source)
- 600 mA output
- Monitors Vout and Iout

DNR-DIO-448

- 48 digital inputs
- Programmable input range
- A/D monitor actual input V

DNR-SL-508

- 8 RS-232/422/485 ports
- Full port-port isolation
- Independent channel settings

DNR-429-566

- 6 ARINC-429 RX channels
- 6 ARINC-429 TX channels
- Hardware label filter/scheduler

DNR-MIL-1553

- 2 dual redundant Mil 1553 channels
- BC, RT or MT/BM operation
- Multiple RT simulation

DNR-DIO-403

- 48 digital I/O
- 5 V logic levels
- 16 mA outputs

DNR-DIO-406

- 24 DIO channels (12 in, 12 out)
- 1 Amp outputs
- 100 kHz updates

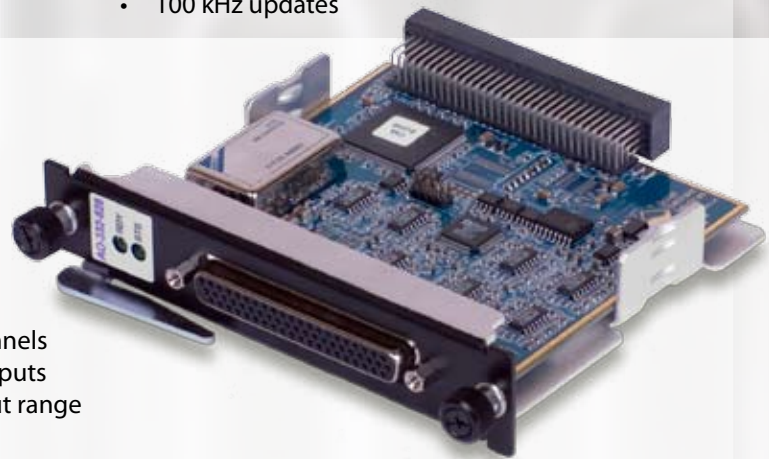

DNR-AO-332

- 32 D/A channels
- ± 10 mA outputs
- ± 10 V output range

DNR-CT-601

- 8 counter/timer channels
- 32-bit counters
- 8 counting modes

DNR-CAN-503

- 4 CAN-bus ports
- Per-port isolation
- 1 Mb/s max xfer rate

Many additional I/O modules are available. Visit www.ueidaq.com for additional details.

FlightSafety
international
Simulation

2700 N. Hemlock Circle
Broken Arrow, OK 74012
Main: (918) 259-4000
Fax: (918) 251-5597
Web: www.flightsafety.com

**United
Electronic
Industries**
High Performance Real-Time I/O and Control

27 Renmar Ave.
Walpole, MA 02081
Main: (508) 921-4600
Fax: (508) 668-2350
Web: www.ueidaq.com